

# FILTER FAILURE DETECTOR



# FILTER FAILURE DETECTOR

## WHAT IT DOES

- Continuous monitoring of fabric filter baghouses for broken bags
- Detects significant changes in particulate emissions
- Provides dual alarm relays (early warning and set maximum limit)
- Minimize false alarms thanks to digital averaging of readings and user selectable delay
- Has a 4-20mA output scaled to 0-200% of the limit alarm level to feed a PLC or other devices
- It's ATEX Zone 2 (Gas) and 22 (Dust) certified



## PRODUCT DESCRIPTION

The main purpose of Goyen | Mecair FFD is to detect significant increases in particulate concentration likely to be related with a broken bag in the filter or other major failures. Thanks to the 4-20 mA output it also acts as an integrated unit to deliver dependable and pragmatic filter monitoring.

The FFD utilizes a unique probe electrification technology which provides much better performances than conventional DC triboelectric systems as well as alternative AC systems. This allows extending the velocity range over which the system has no cross sensitivity to changing velocity. Thanks to that technology, the FFD is also unaffected by build-up of particulate on the sensing rod, thus eliminating signal drift concerns.

A charge signature is induced by particulates in the airstream interacting with the sensing rod. The FFD extracts a specific frequency band from the induced AC current signature and filter out the DC current generated by direct particle collisions. In order to reject signals falling outside a pre-defined frequency range, the so resulting signal is electronically filtered. Thanks to that, Goyen | Mecair filter failure detectors are less susceptible to changes in particle velocity and are not affected by any particulate contamination on the sensing rod.

Also this technology, not relying on particles colliding with the probe, is able to measure a more representative area of the stack and eliminate the need of long sensor probe rods.

Thanks to the digital averaging of readings in combination with the alarm delay feature, by properly setting the delay period, the system will exclude short term signal increases associated with pulse cleaning of filters. This translates into a much lower likelihood of having false alarms.

## OPERATIONAL RANGE

- Suitable for a wide range of dust collectors designs and configurations
- Dust level response: <math><1\text{mg}/\text{m}^3\text{ to }500\text{mg}/\text{m}^3</math> (<math><0.028\text{ mg}/\text{ft}^3\text{ to }14\text{ mg}/\text{ft}^3</math>)
- Flue gas velocity from 4m/sec
- Flue gas temperature up to 200°C (390°F)
- Ambient temperature from -20°C to +50°C (-4°F to +120°F)
- Duct sizes from 0.5m
- Hazardous area ATEX II 3GD

## BENEFITS

- Reduce plant downtime thank to real-time emission monitoring for preventive maintenance
- Detects and anticipates filter failures due to (i.e.) broken bags
- Suitable for all particles regardless of composition
- Extremely wide range of concentration and mass flow
- Seamless interface into industrial controls systems, such as PLC
- Unaffected by build-up of particulate on sensing rod
- Data averaging and alarm delay user selectable to avoid false alarms
- Measurement does not drift due to electrostatic charging

## FEATURES

- Dependable 4-20 mA, scaled from 0-200% for higher readings accuracy
- Dual relay outputs
- Alarm level adjustment
- Alarm delay time adjustment
- Sensor sensitivity adjustment
- Unique probe electrification technology
- ATEX II 3GD compliant

## PROCESS AND APPLICATION CONDITIONS

Stack temperature range	-20 to 200°C (-4 to 390°F)
SENSOR - KEY DATA	
Flue gas velocity	>4 m/s
Dust level response	<1 to 500 mg/m <sup>3</sup> (dependent upon application)
Application conditions	Suitable for measurement in non-condensing flue gases. <b>Note:</b> not recommended for deployment downstream of ESPs or in applications with water droplets or mist at monitoring point.
ENVIRONMENTAL INFORMATION	
Location	This equipment is for outdoor or sheltered use.
Altitude category	2,000m (6,500 ft.), max.

## SENSOR SPECIFICATION

FFD SENSOR	
Sensor variants	Standard sensor: 0-200°C (up to 390°F)
Weight	approx. 1930 g (4.3 lb)
Probe rod material	316 Stainless Steel, PTFE (insulator)
Cable entries	2x M16 cable glands
ENCLOSURE	
Ambient temperature range <sup>c</sup>	-20 to +50°C (-4 to 120°F)
Dimensions	W 111 x H 135 x D 74 mm (4.4 x 5.3 x 3 in.), excl. cable glands
Protection rating	IP65
Material	Die-cast aluminium LM6M (epoxy coated)
POWER REQUIREMENTS	
Power supply voltage	16-24 V DC
Current consumption	max. 100 mA
I/O	
Local outputs	2x Alarm relays: <ul style="list-style-type: none"> <li>• volt-free SPCO</li> <li>• current rating 1 A DC (@ 30 V) per contact</li> <li>• non-fail-safe operation only.</li> </ul> 1x 4-20 mA output: 250Ω, non-isolated.

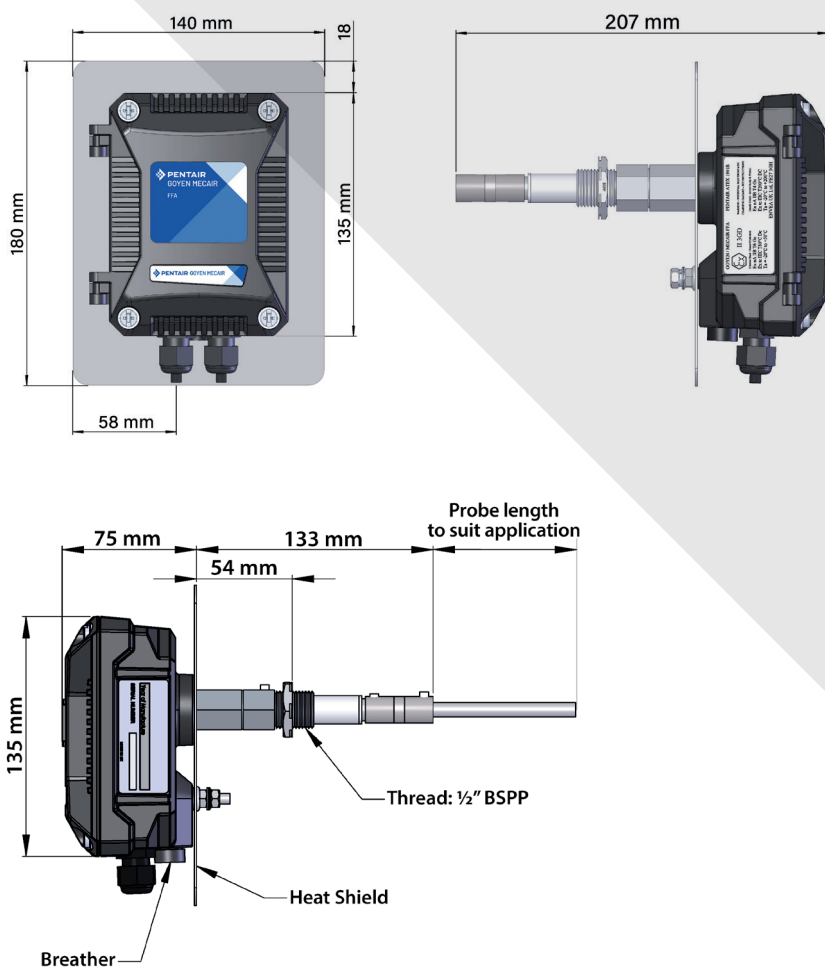

**PROBE ROD LENGTH** 300mm | 600mm | 1000mm

**ORDERING CODES** Please note that along with the FFD code you must always order either the F300, F600 or F1000 (respectively for the 300 mm long rod, the 600 mm long rod and the 1000 mm long rod)

**NOTES** Imperial temperatures given are nominal values



**CLEAN AIR SYSTEMS**

GOYEN CONTROLS CO. PTY. LTD., 268 - 292 MILPERRA RD, MILPERRA NSW 2214, PH: +61 1800 805 372, FX: +61 1300 658 799  
 MECAIR SRL, VIA BERTACCIOLA, 50, 20813 BOVISIO MASCIAGO (MB), ITALY, PH: +39 0362 3751, FX: +39 0362 3672 79  
 WWW.GOYENMECAIR.PENTAIR.COM

Note: The information and data contained in this document are based on our general experience and are believed to be correct. They are given in good faith and are intended to provide a guideline for the selection and use of our products. Since the conditions under which our products may be used are beyond our control, this information does not imply any guarantee of final product performance and we cannot accept any liability with respect to the use of our products. The quality of our products is guaranteed under our conditions of sale. Existing intellectual property rights must be observed.  
 BROCC FFD EN 2819 © 2019 Pentair. All Rights Reserved.